

THIS DRAWING IS UNPUBLISHED. RELEASED FOR PUBLICATION
 © COPYRIGHT BY TYCO ELECTRONICS CORPORATION. ALL RIGHTS RESERVED.

LOC	DIST	REVISIONS			
P	LTR	DESCRIPTION	DATE	DWN	APVD
		AF1	REVISED PER ECO-06-018765	13APR07	DH DB

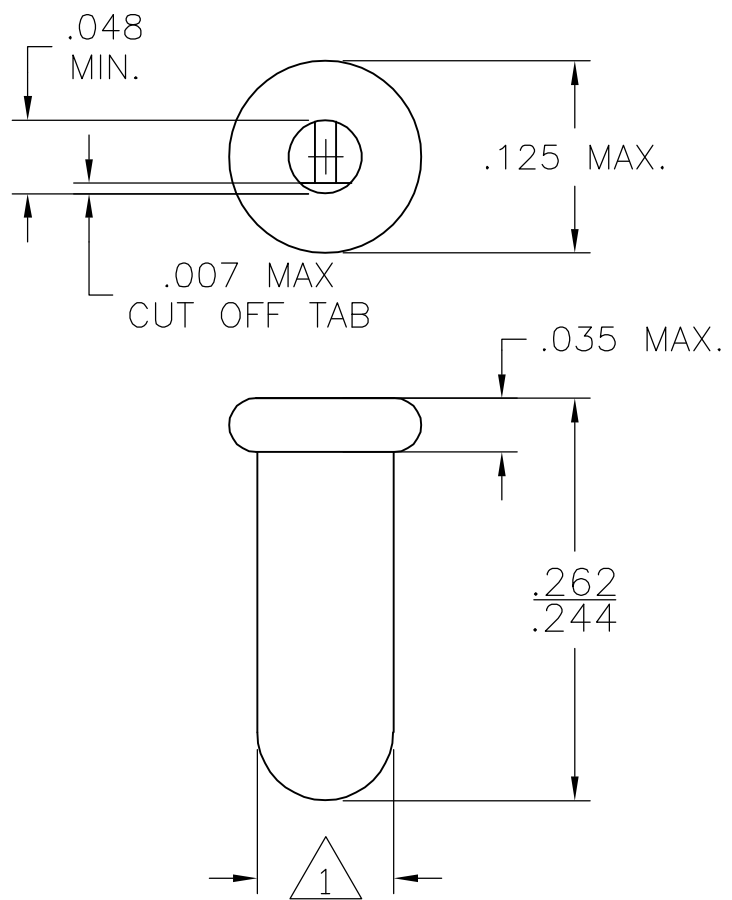

- 1 PART FITS INTO A #43 DRILLED HOLE(.089±.0015) FOR HAND INSERTION AND A #44 DRILLED HOLE(.086±.0015) FOR MACHINE INSERTION.
- 2 .145 MIN. INSERTION DEPTH REQUIRED FOR A RELIABLE CONNECTION.
- 3. SPRING TO BE SECURED IN CUP WITH NO SPRING ROTATION PERMISSIBLE.
- 4. LEAD RANGES & PERFORMANCE RESULTS.

LEAD RANGES (DIA)	.018-.020	.025-.032	.035-.040
MAX. INSERTION FORCE	17 oz.	37 oz.	48 oz.
MIN. EXTRACTION FORCE	1.0 oz.	1.5 oz.	2.0 oz.
MILLIVOLT DROP (MAX.)	2.00 MV	1.75 MV	1.50 MV

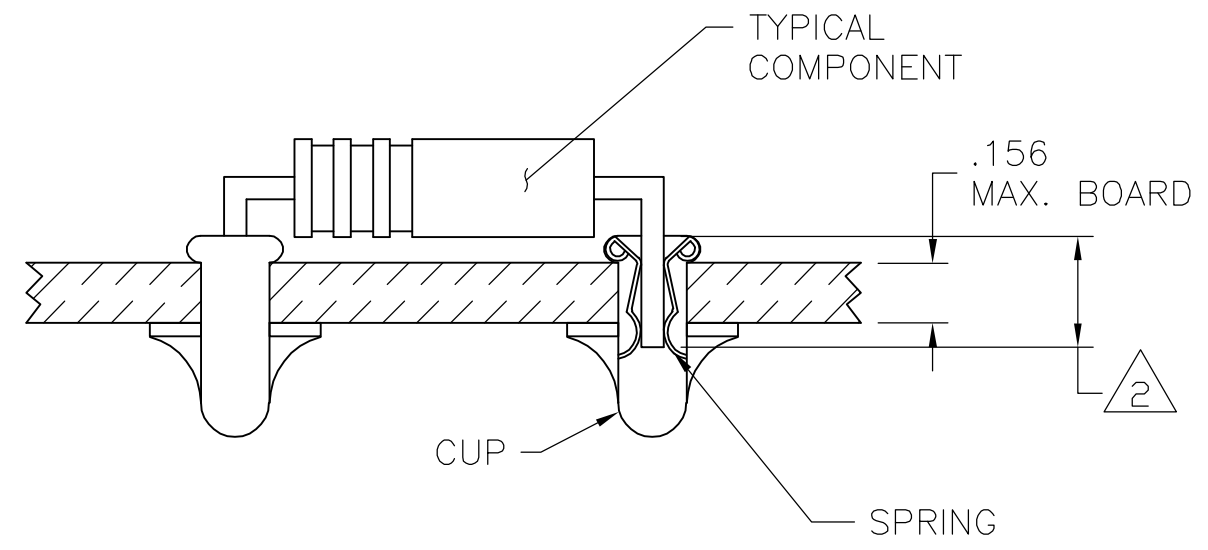

OBSOLETE	.000150 MIN BRIGHT TIN	.000030 MIN GOLD OVER .000030 MIN NICKEL	380598-6
OBSOLETE	.000050 MIN GOLD OVER .000050 MIN NICKEL	.000050 MIN GOLD OVER .000050 MIN NICKEL	380598-5
OBSOLETE	TIN-LEAD	TIN-LEAD	380598-4
OBSOLETE			380598-3
			380598-2
	.000030 MIN GOLD OVER .000030 MIN NICKEL	.000030 MIN GOLD OVER .000030 MIN NICKEL	380598-1
NOTES	CUP	SPRING	PART NO.
	FINISH		

THIS DRAWING IS A CONTROLLED DOCUMENT. DWN D. HUMBERT 13APR2007

CHK -

APVD -

PRODUCT SPEC -

APPLICATION SPEC -

WEIGHT -

CUSTOMER DRAWING

tyco Electronics Tyco Electronics Corporation
Harrisburg, PA 17105-3608

REUSEABLE COMPONENT RECEPTACLE

SIZE A3 CAGE CODE 00779 DRAWING NO C-380598 RESTRICTED TO -

MATERIAL CUP - Cu SPRING - BeCu FINISH SEE TABLE

SCALE NTS SHEET 1 OF 1 REV AF1