

THIS DRAWING IS UNPUBLISHED. RELEASED FOR PUBLICATION .19
 © COPYRIGHT 19 BY AMP INCORPORATED. ALL RIGHTS RESERVED.

LOC		DIST		REVISIONS			
P	LTR	DESCRIPTION		DATE	DWN	APVD	
AF	50	G		REV PER ECR 06-010492	02OCT06	MF	GP

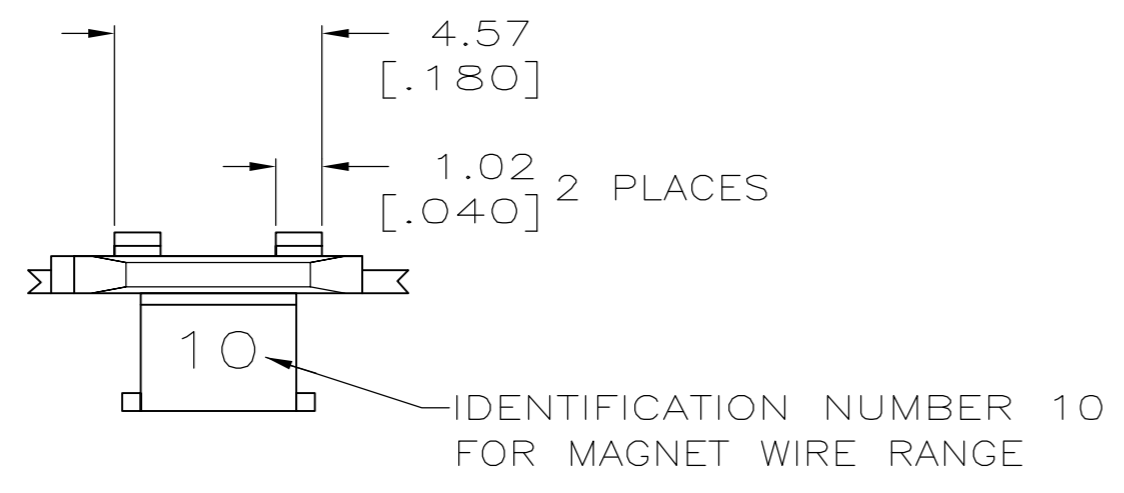

1 CONTINUOUS STRIP ON REELS WITH TERMINALS LOCATED ON 8.38±0.08 [.330±.003] CENTERS.
 2 SLOT ACCEPTS 0.36-0.58mm [#27-#23] AWG COPPER MAGNET WIRE. TWO WIRES OF THE SAME SIZE MAX PER SLOT.

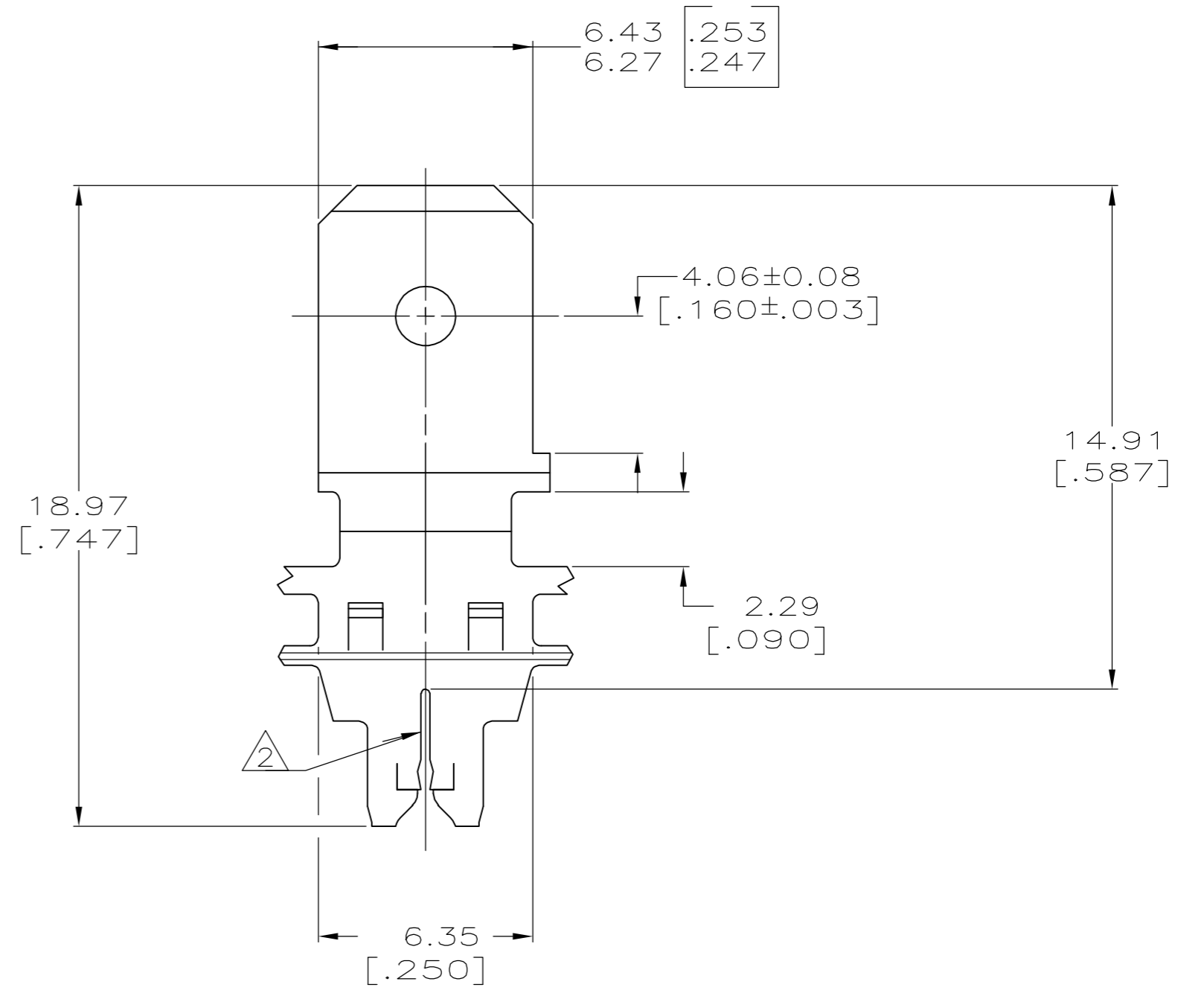
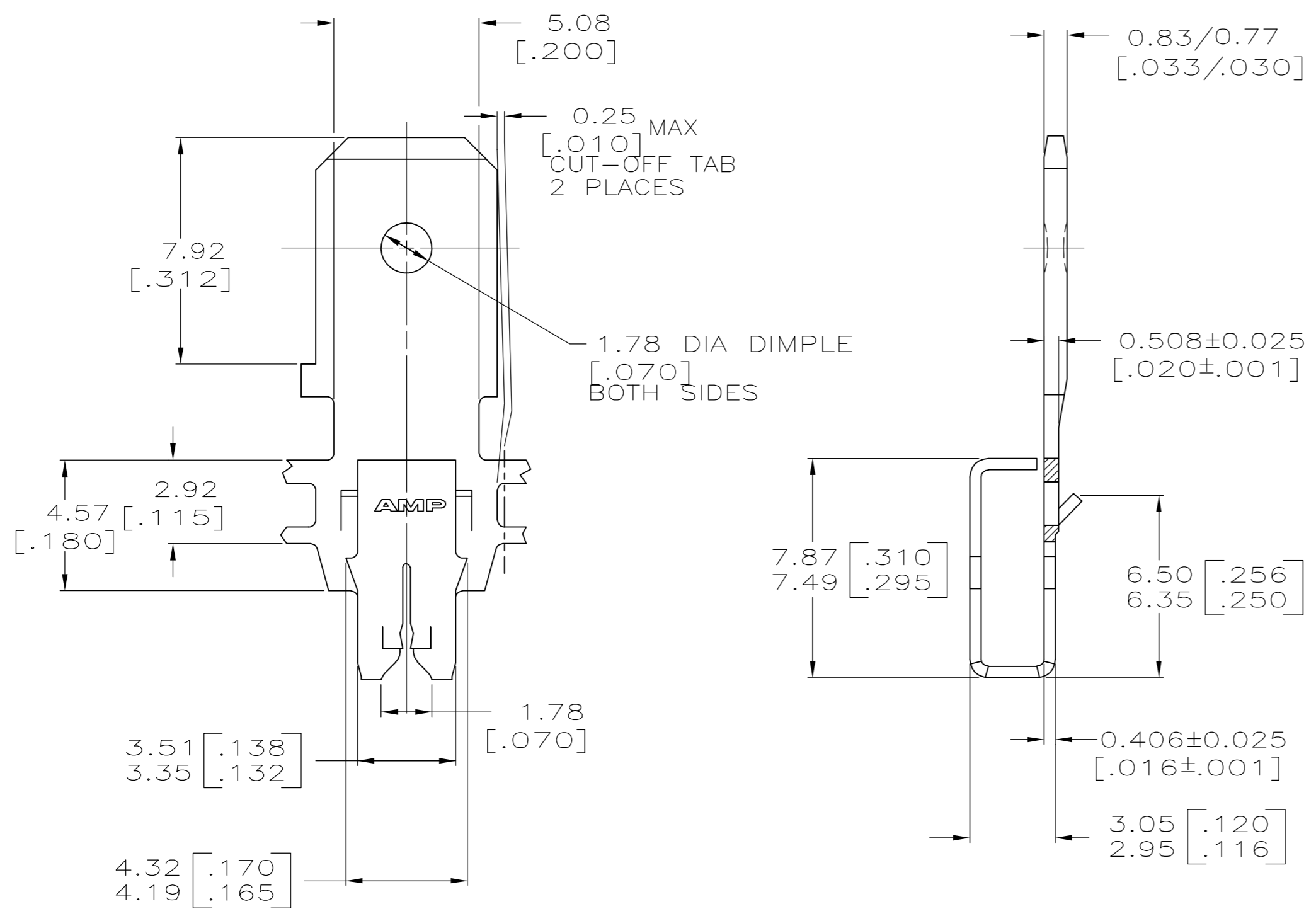

082 PRE-MILLED BRASS	63128-3
4M PRE-MILLED BRASS	63128-1
MATERIAL	PART NUMBER

THIS DRAWING IS A CONTROLLED DOCUMENT.

DWN MICHAEL S. FEHER 07FEB97	CHK RICHARD GRZYBOWSKI 10FEB97	APVD NELSON E. NEFF 10FEB97	NAME
PRODUCT SPEC 108-2012			AMP Incorporated Harrisburg, PA 17105-3608
APPLICATION SPEC 114-2094			TAB, 6.35[.250] FASTON,™ MAG-MATE™
MATERIAL SEE TABLE	FINISH 0.002032[.000080] MIN TIN PER MIL-T-10727	WEIGHT -	SIZE A2
CUSTOMER DRAWING		SCALE 6:1	DRAWING NO C=63128
		SHEET 1 OF 1	REV G